

# FREZNO 150 TW

## USER MANUAL

 <sup>®</sup> FREZNO 150 TW  
SS816

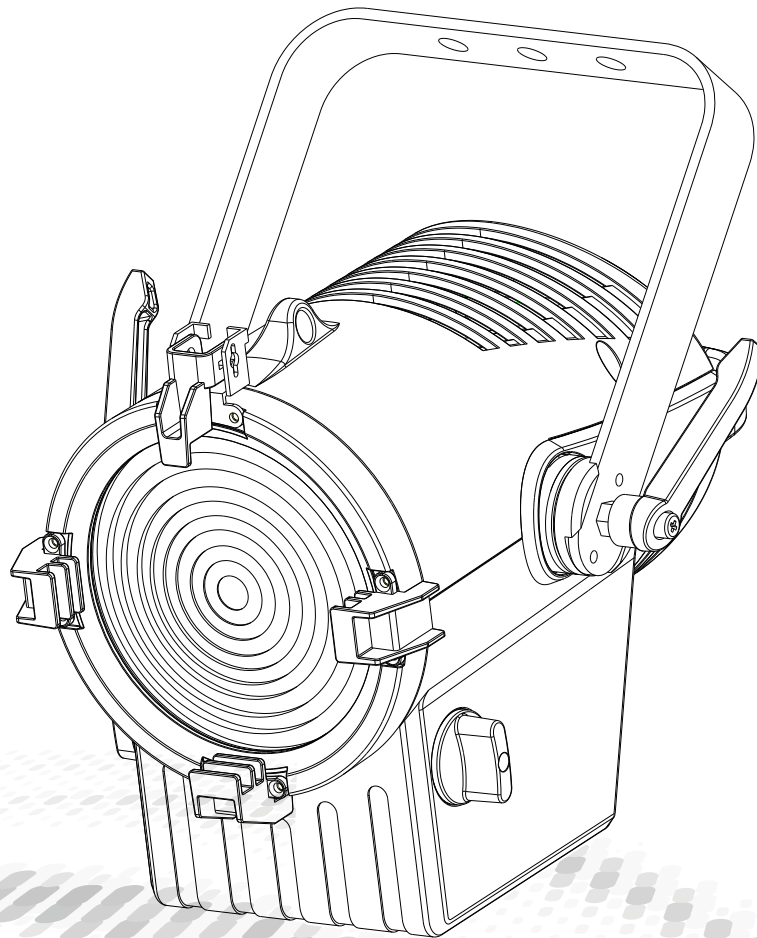

**MODEL:SS816TW**



— Since 1985 —

广州市雅江光电设备有限公司

Guangzhou Yajiang Photoelectric Equipment Ltd.

电话/Tel : 020-86947788 邮箱/E-mail : sales@yajiang.cn

传真/Fax : 020-86943773 网址/Website : www.yajiang.cn

# 1 PRODUCT INTRODUCTION

## 1.1 SPACIFICATION

Product Code	SS816TW
Dimenson	321x363x274(mm)
Weight	5.3KG
Rated power	120W
Input Voltage	AC100~240V
Maximum Temperature	50/60Hz
Ambient Temperature	0°C~45°C
Beam Angle	10°~55°
Control Model	DMX512/RDM

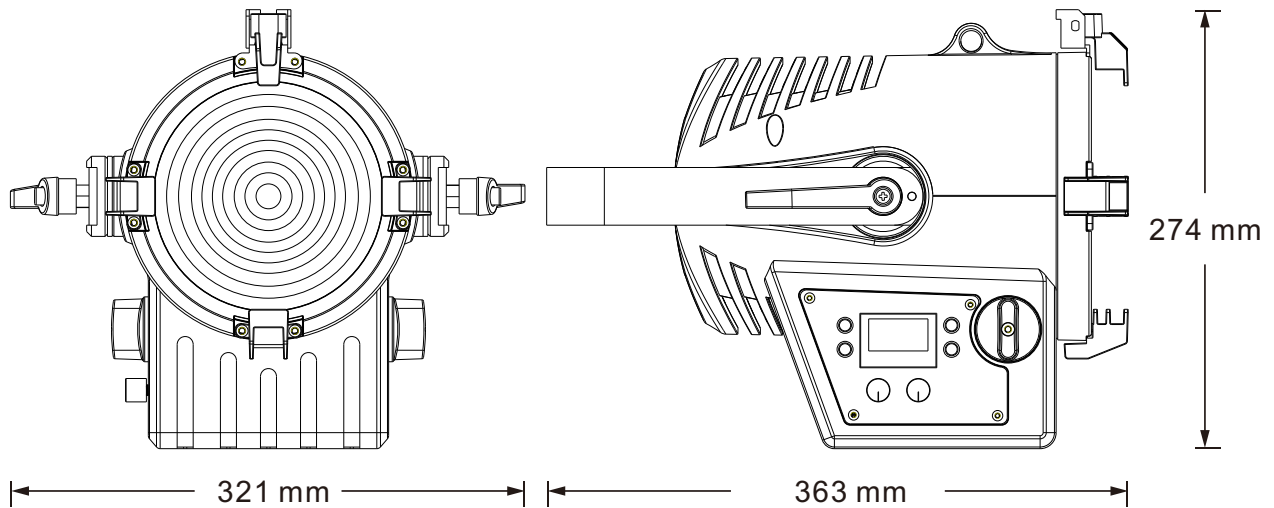

## 1.2 Safety warning

### IMPORTANT

Always read the user manual before operation.

Please confirm that the power supply stated on the product is the same as the mains power supply in your area.

- This product must be installed by a qualified professional.
- Always operate the equipment as described in the user manual.
- A minimum distance of 0.5m must be maintained between the equipment and combustible surface.
- The product must always be placed in a well ventilated area.
- Always make sure that the equipment is installed securely.
- Do not stand close to the equipment and stare directly into the LED light source.
- Always disconnect the power supply before attempting and maintenance.
- Always make sure that the supporting structure is solid and can support the combined weight of the products.
- The earth wire must always be connected to the ground.
- Do not touch the power cables if your hands are wet.
- Please protect the fixture and avoid destroy during transport and installation. If there is any damage of the coating, that will influence the sea-salt and waterproof function.

### ATTENTION



- This product left the place of manufacture in perfect condition. In order to maintain this condition and for safe operation, the user must always follow the instructions and safety warnings described in this user manual.
- Avoid shaking or strong impacts to any part of the equipment.
- Make sure that all parts of the equipment are kept clean and free of dust.
- Always make sure that the power connections are connected correct and secure.
- If there is any malfunction of the equipment, contact your distributor immediately.
- When transferring the product, it is advisable to use the original packaging in which the product left the factory.
- Shields, lenses or ultraviolet screens shall be changed if they have become damaged to such an extent that their effectiveness is impaired.
- The lamp (LED) shall be changed if it has become damaged or thermally deformed.



**Caution, risk of electric shock**  
**The light source contained in this luminaire shall only be replaced by the manufacturer or his service agent or a similar qualified person.**

## 2 INSTALLATION

### 2.1 Mounting

The fixture can be mounted in any position.

Always ensure that mounting surface can withstand 10 times the weight of the fixture.

Always use a safety cable when mounting the fixture in any elevated position.

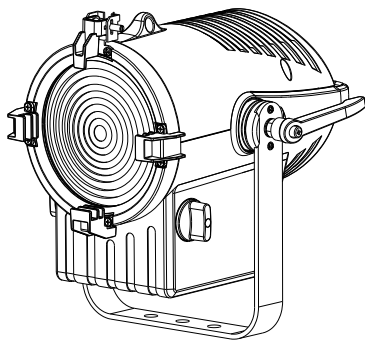

UPRIGHT

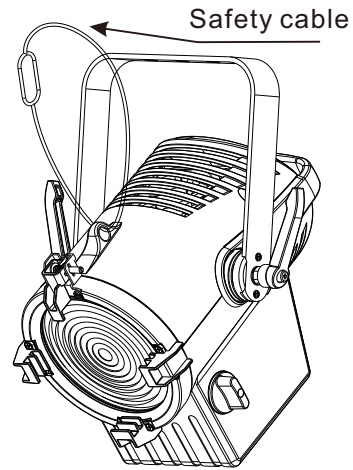

HANGING

- Important safety note!!
- Always use safety cable when installing this unit!!
- Be sure that the safety cable is connected to a solid load-bearing structure.

## 2.2 Power connections

This product uses input and output power cable is 1.5 square mm copper wire

Note:

If the signal cable is over 60m between the DMX512 controller and fixture or between two fixtures, then a DMX signal amplifier is needed as well.

## 2.3 The control station setting of connecting DMX512

The DMX console and the lamp body are connected in series.

Because the Std.P MODE is five channels, the address code of the lamp increases by 5 times such as(1,6,11,16...),also each it can be reused as needed.

The DMX address code can be any value between 001and 512.

DMX Addr.X      DMX Addr.X+1      .....

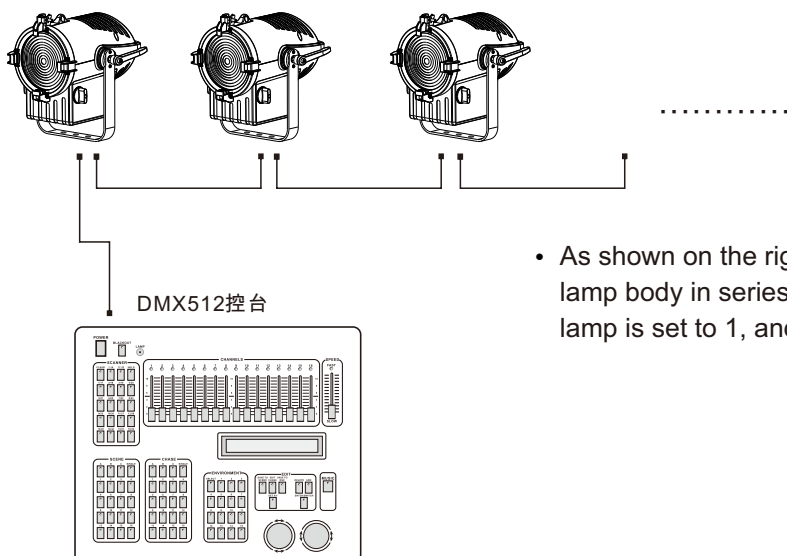

- As shown on the right, the controller is connected to the lamp body in series, the DMX address code for the first lamp is set to 1, and second unit is set to 6, and so on.

# 3 Display panel operation

## 3.1 Display operation

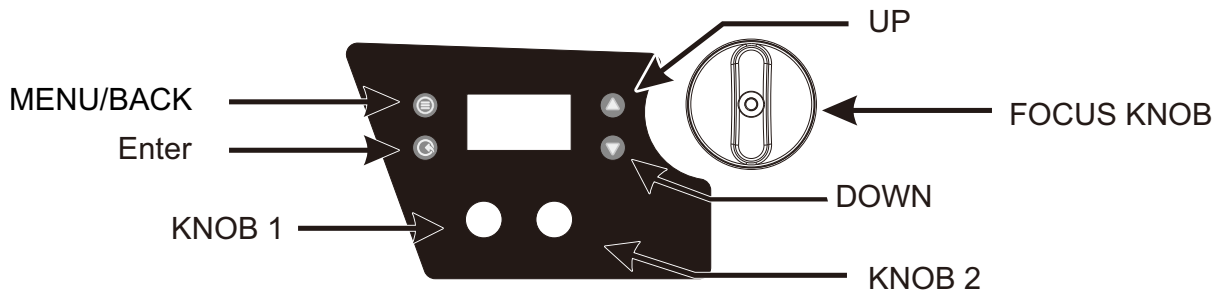

## 3.2 MENU

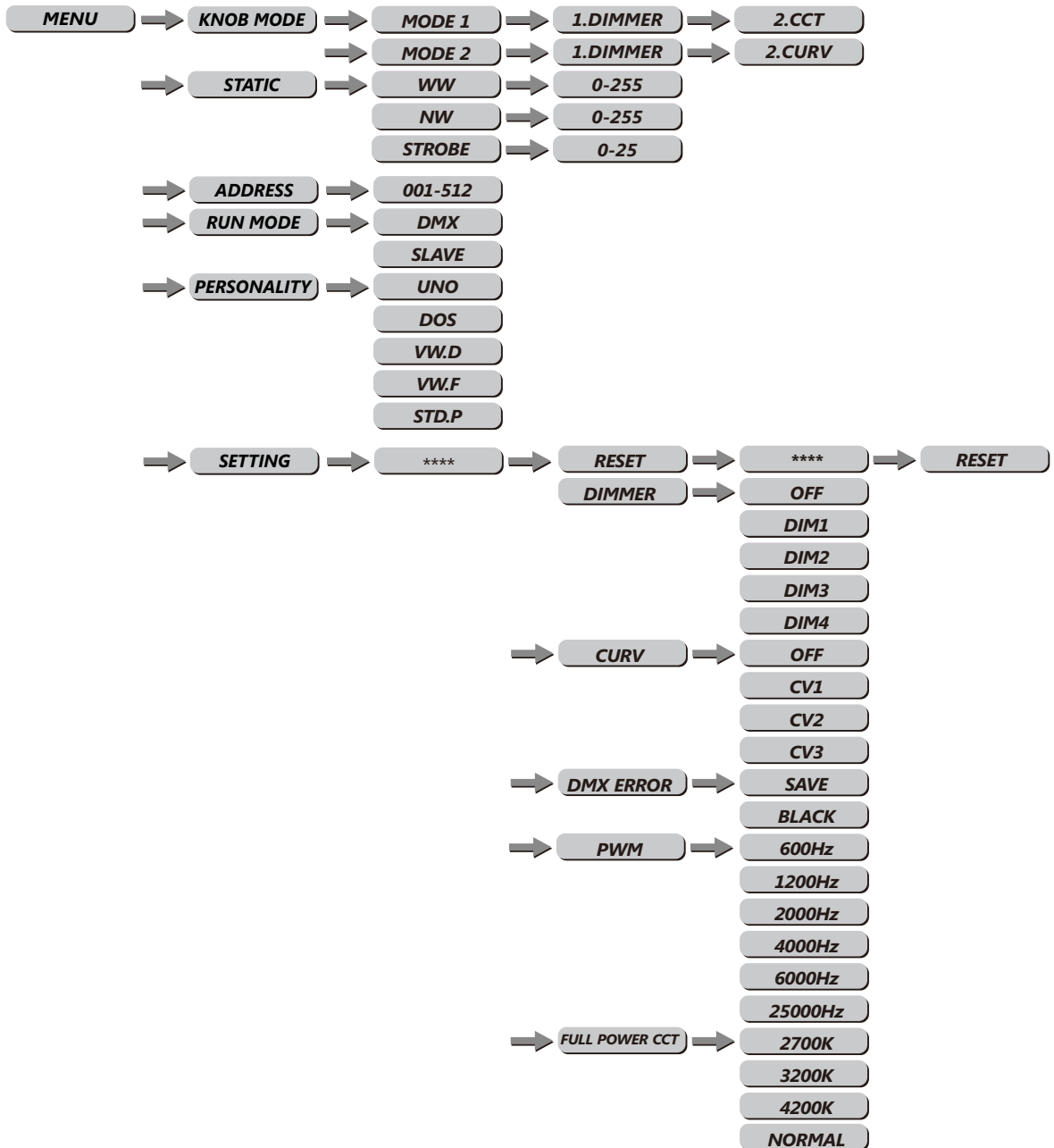

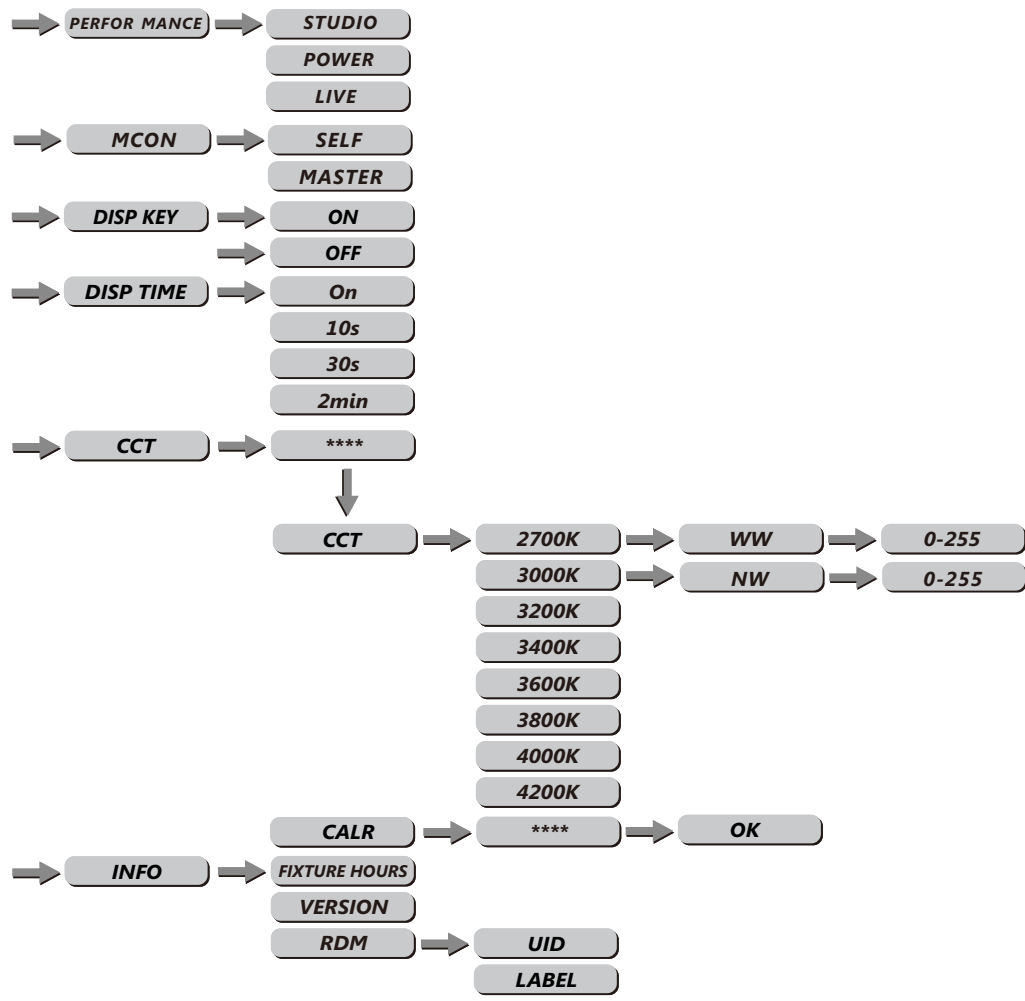

### 3.3 KNOB SETTING

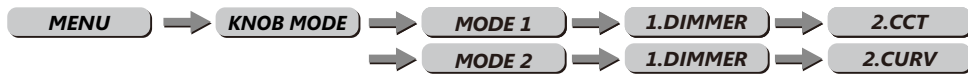

- Press Enter to enter **MANUAL MODE** to enter the knob settings:  
**MODE 1:** When MODE1 is selected, DIMMER dimming brightness can be set by knob 1; CCT management can be set by rotating 2
- **MODE 2:** When MODE2 is selected, DIMMER dimming brightness can be set by knob 1; COLOR can be set by rotating 2

### 3.4 STATIC

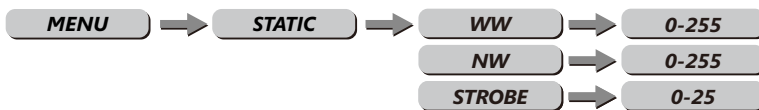

- Enter the STATIC mode to create the programs
- Combine WARM/NATURE/STROBE to create a definite range of colors ,Push up and down buttons adjust 0~255 value,Set value of the STROBE,Push up and down buttons adjust 0~25Hz value
- The static setting will be valid when the fixture is powered again.

### 3.5 DMX Address Setting



- enter the DMX mode to set the dmx address.
- enter up/down select 1~512 address.
- enter menu return.

### 3.6 RUNMODE

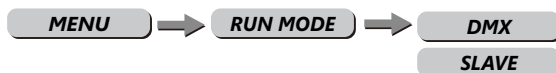

- **RUNMODE** menu, select required run mode,there are any modes inside:DMX mode,SLAVE mode, press Down/Up select mode.
- DMX mode is for using the DMX controller to control the fixtures.  
SLAVE mode is for Master -- Slave operation.
- Press Enter accept,press MENU return.

### 3. 7PERSONALITY



- Press enter the menu to do a custom choice on the 'PERSONALITY' menu.
- Press UP or DOWN to select UNO,DOS,VW.D,VW.F,STD.P.
- Please refer to DMX channel table for the specific channel value .

### 3.11 SETTING

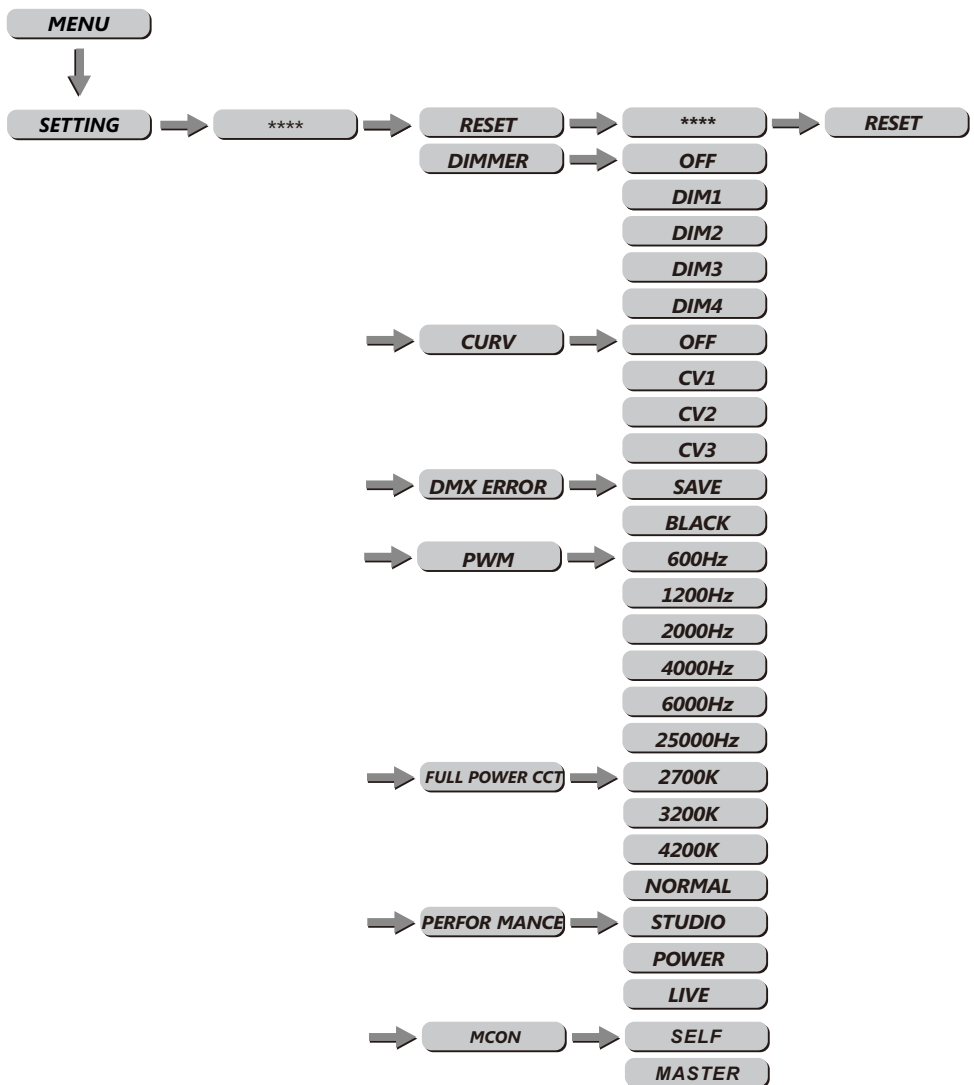

- **SETTING** : this menu allows the user to adjust key operation settings for this fixture.
- **RESET** : RESET the lamp. Enter the password "up down up down " to confirm, and then perform the RESET of the lamp parameters.
- **DIMMER** : tis a non-linear DIMMER speed setting "OFF" is a normal linear dimming Select **DIM1**, **DIM2**, **DIM3** or **DIM4** for different dimming speeds. (DIM4 is the slowest dimming speed).
- **CURV** : allows the user to adjust the shape of the dimming curve. See the CURV chart to Understand more about actual dimming curves.
- **DMX ERROR** : Choose SAVE in order to save the last DMX data incase of DMX signal error.Choose BLACK in order to blackout in case of DMX signal error.
- **PWM** : is PWM refresh rate bottom, press UP/DOWN to choose <600Hz>, <1200Hz>, <2000Hz>, <4000Hz>, <6000Hz>, <25000Hz>. Note: Attention: The gray level of dimming will be reduced as the refresh rate increases.
- **FULL POWER CCT** : is the color temperature choose bottom, press UP/DOWN to choose, under full power, 2700K,3200K,4200K,Normal.
- **PERFOR MANCE** : menu, select<STUDIO/POWER/LIVE>as required fan speed.
- **MCON**:this function allows the user to select whether the fixture will send DMX data to other fixtures during stand-alone operation. The [MAST] setting allows data to be sent to Other fixtures. The [SELF] setting is default and will not send DMX data to other fixtures. Note: When using this function, if the [MCON] menu is set as [MASTER], then the fixture will transfer the [DIM] values to other fixtures. When DMX data is received at the fixture, it will automatically return to main menu after 2 minutes of no key

### 3.12 ACTIVATE THE PASSWORD



- Enter the **KEY** mode to select whether the access password is on or off. When the fixture is set as PASS"ON", after 30 seconds or turn on the fixture next time, the fixture will need an access password to enter the display menu control.
- Note: The factory access password is"UP+DOWN+UP+DOWN",then press ENTER to confirm the access.

### 3.13 DISP TIME SETTING



- The time of the display lights up:  
 ON: The screen will automatically protect if 30 seconds without operation.  
 10s/30s/2min: The screen continues to light up

### 3.14 CALIB.CCT

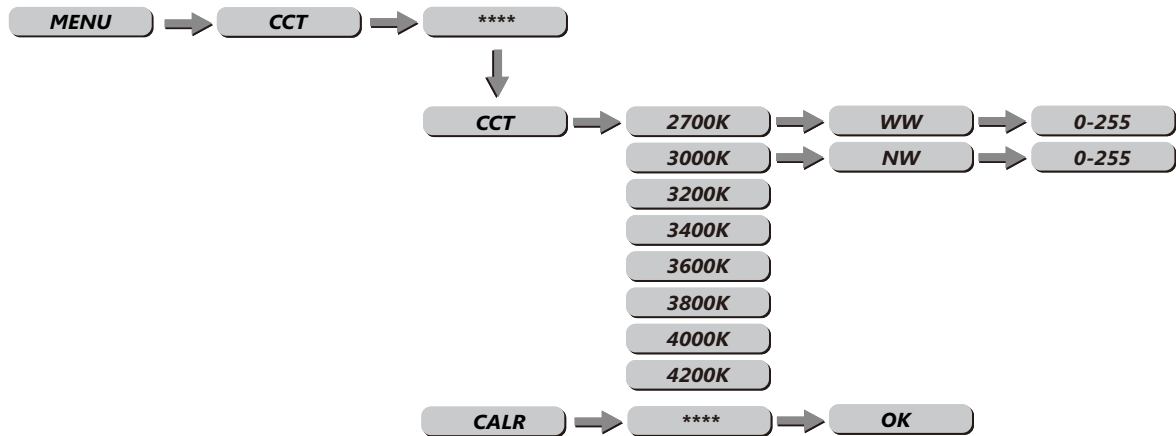

- Enter the **CALIB.CCT** to select white color of different color temperature.
- Press MENU button to enter the password confirmation, to enter the correct password < UP + DOWN + UP + DOWN >Key.
- correct password < UP + DOWN + UP + DOWN >Key, press the MENU in, the correct password will enter show submenu.
- Select CALR press enter,input password<UP+DOWN+UP+DOWN>,if your password correct there will restore default factory Settings.

### 3.15 INFO

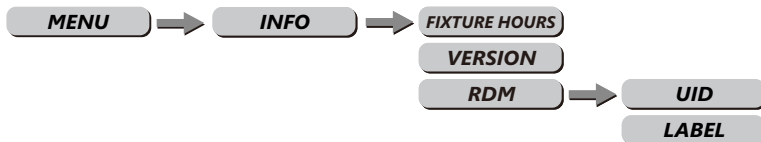

- Press Enter into **INFO** check information,press up and down
- **FIXTURE HOURS** : is hours of fixture use.
- **VERSION** : is software versions.
- **RDM** : check fixture's ID.

# 4 Using a DMX512 Controller

## 4.1 Channel Assignment

Note: this product have DMX512 channel configuration: UNO/DOS/VW.D/VW.F/STD.P

UNO	DOS	VW.D	VW.F	STD.P	Value	Function
CH.1	CH.1	CH.1	CH.1	CH.1	0-255	DIMMER
	CH.2		CH.2	CH.2	0-255	DIMMER FINE
		CH.2	CH.3	CH.3	0-255	WARM WHITE
			CH.4	CH.4	0-255	WARM WHITE FINE
		CH.3	CH.5	CH.5	0-255	NATURAL WHITE
			CH.6	CH.6	0-255	NATURAL WHITE FINE
				CH.7	<b>CCT</b>	
					0-010	NO FUNCTION
					11-35	2700K
					36-60	3000K
					61-85	3200K
					86-110	3400K
					111-135	3600K
					136-160	3800K
					161-185	4000K
					186-210	4200K
					211-255	NO FUNCTION
				CH.8	<b>Effect of center STROBE</b>	
					0-9	NO FUNCTION
					10-99	STROBE FROM (SLOD TO FAST , 0-25Hz)
					100-109	NO FUNCTION
					110-179	LIGHTNING STROBE
					180-189	NO FUNCTION
				190-255	RANDOM STROBE	